



For Sale or Lease

1034 Home Ave.

Akron, Ohio

Property Description

Building Size:	54,800 sq.ft. ±
Warehouse:	51,300 sq.ft. ±
Office:	3,500 sq.ft. ±
Land:	2.18 Acres ±
Ceiling Height:	12' - 16'
Docks:	5
Year Built:	1967—1998
Parking:	40
Sale Price Reduced to:	\$875,000.00

Comments: Partially Air Conditioned. Former printing facility. Recent 60 mil Carlisle roof. 16.3 miles from Akron-Canton Regional Airport

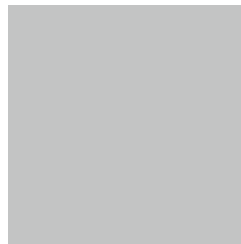
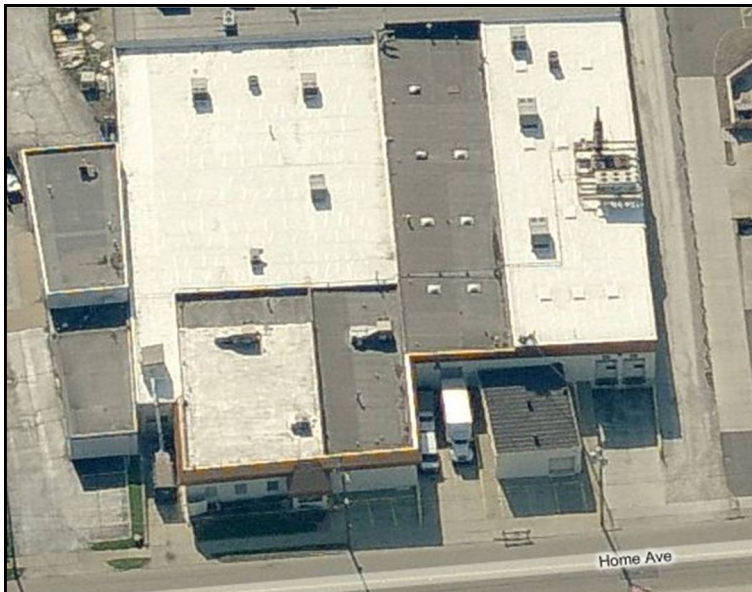

Commercial Real Estate Services, Worldwide.

Business Property Specialists, Inc. Broker

This information has been secured from sources we believe to be reliable, but we make no representations or warranties, expressed or implied, as to the accuracy of the information. References to condition, square footage or age are approximate. Buyer or Tenant acknowledges that they are relying on their own investigations and are not relying on Broker provided information.

contact information

William K. Sadataki
23240 Chagrin Blvd., Suite 250
Cleveland, OH 44122
www.naidaus.com
tel 216 831 3310 ext. 175
fax 216 831 9869
wsadataki@naidaus.com

1034 Home Avenue Floor Plan

Akron, Ohio

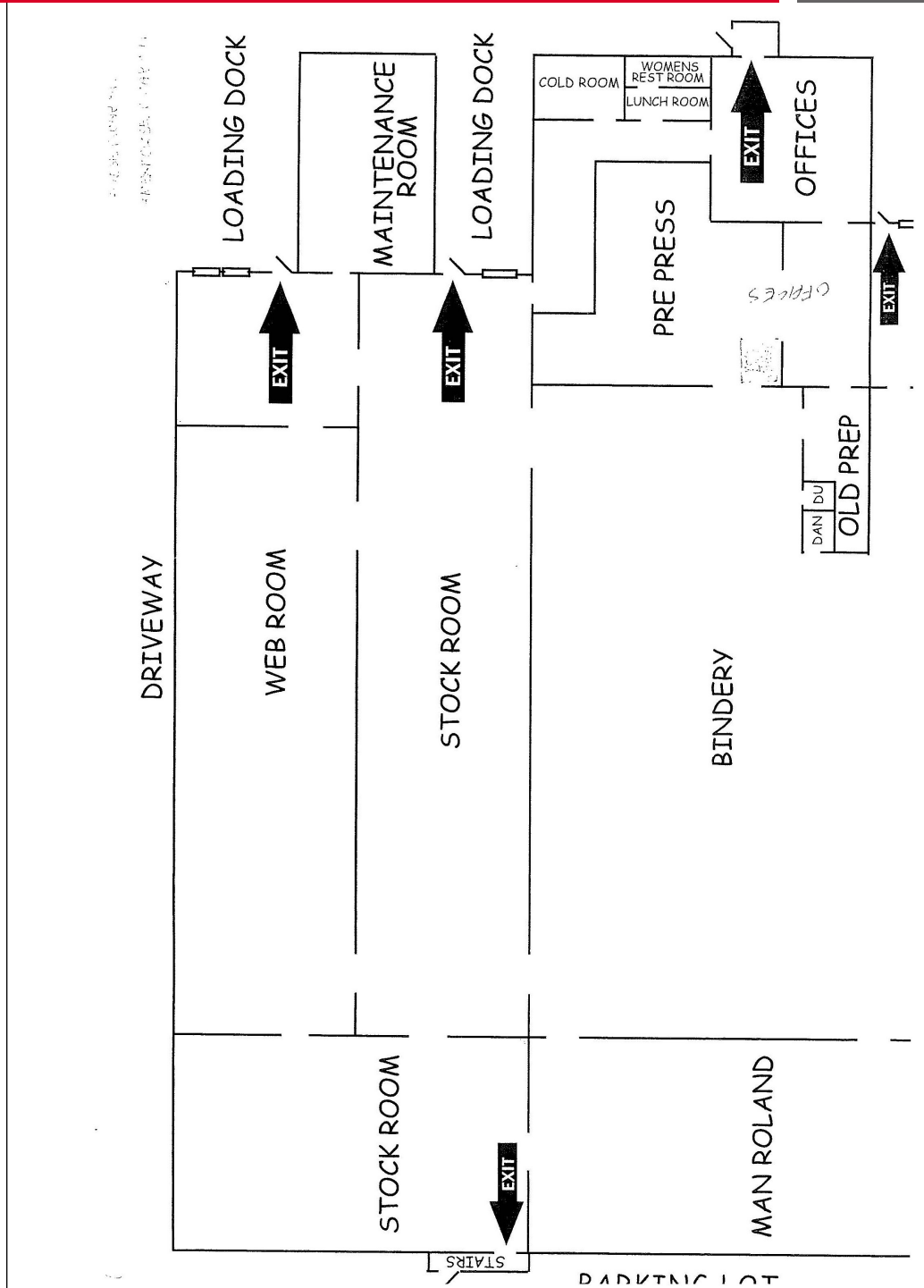

contact information

William K. Sadataki

23240 Chagrin Blv d., Suite 250

Cleveland, OH 44122

www.naidaus.com

tel 216 831 3310 ext. 175

fax 216 831 9869

wsadataki@naidaus.com



Commercial Real Estate Services, Worldwide.

Business Property Specialists, Inc. Broker

This information has been secured from sources we believe to be reliable, but we make no representations or warranties, expressed or implied, as to the accuracy of the information. References to condition, square footage or age are approximate. Buyer or Tenant acknowledges that they are relying on their own investigations and are not relying on Broker provided information.